

Fieldwork Surveying FS01

- Ing. Tomáš Křemen Ph.D.
- Office B905
- <http://k154.fsv.cvut.cz/~kremen/>
- <https://k154.fsv.cvut.cz/vyuka/english/fs01/>

Fieldwork Surveying FS01

1. Lecture

Introduction

Presentation was supported by 105 1052201A003 FCE CTU in Prague Internal Project

Geodesy (surveying) – one of the earth sciences, geodesy is concerned with measurements of the Earth and with the Earth's surface representation

1. theoretical → geodesy
2. practical → surveying

Projection of points to a horizontal projection surface

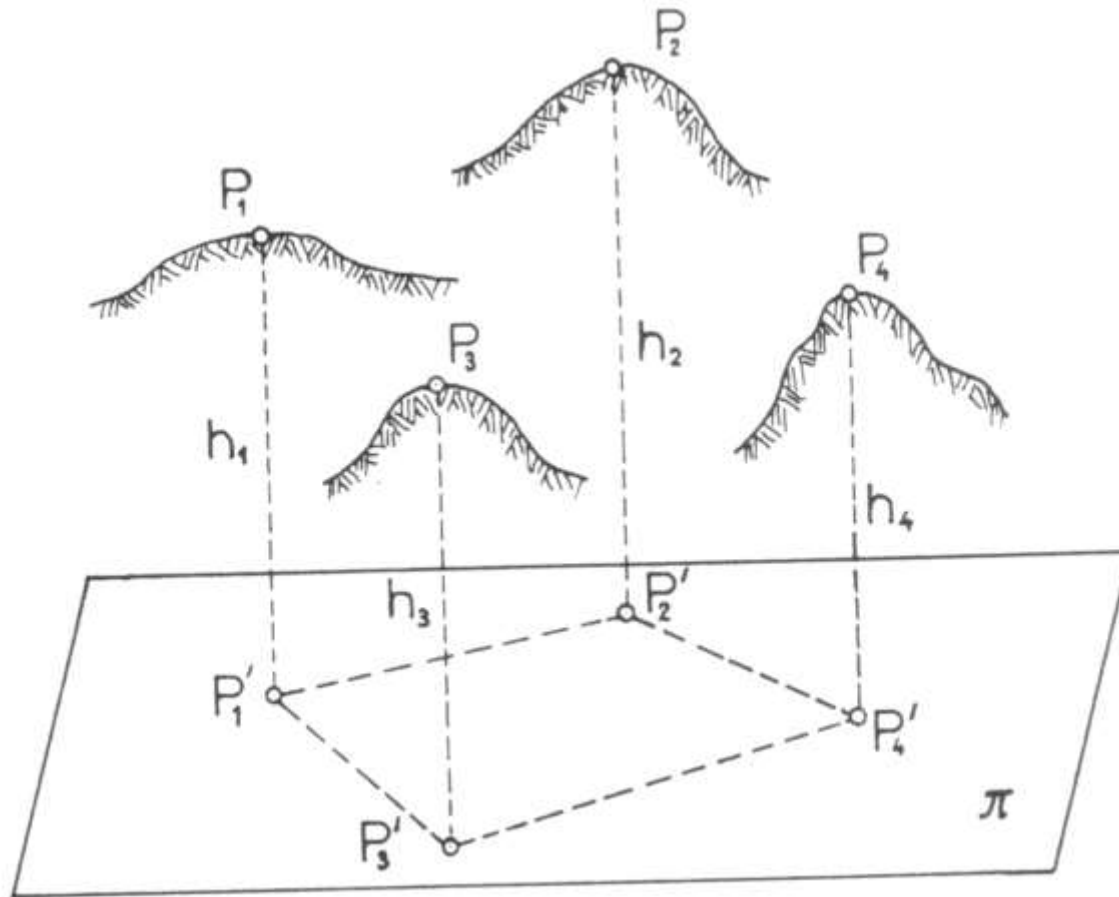

Planimetric component of a map = image of the Earth's surface which represents subjects of survey positioning (set of points, lines and map symbols).

Altimetry = graphic representation of the Earth's relief (contour lines, peak elevations).

Map = image of subjects of planimetric and (or) altimetric survey,
= result of measurements.

Shape and size of the Earth, reference surfaces

Earth = a physical solid whose shape is created and maintained by the gravity.

The real Earth surface is irregular and its mathematical formulation is not possible. Therefore it is replaced by a closed surface which is perpendicular to the force of gravity = equipotential surface.

There are an infinite number of equipotential surfaces (they differ in the gravity potential).

The most important is the zero surface which comes through the zero height point.

Geoid = solid created by the zero surface,

- similar to the real Earth surface
- very difficult to express mathematically.
- it is used for theory of heights

Rotational ellipsoid = an „easy“ mathematical formulation

there are solved basic geodetic problems
(in position)

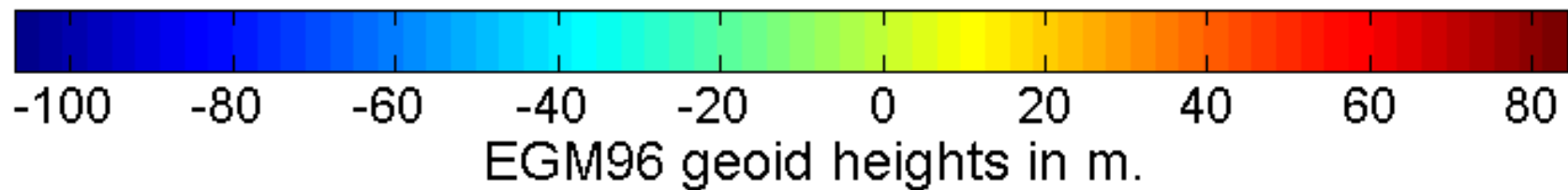
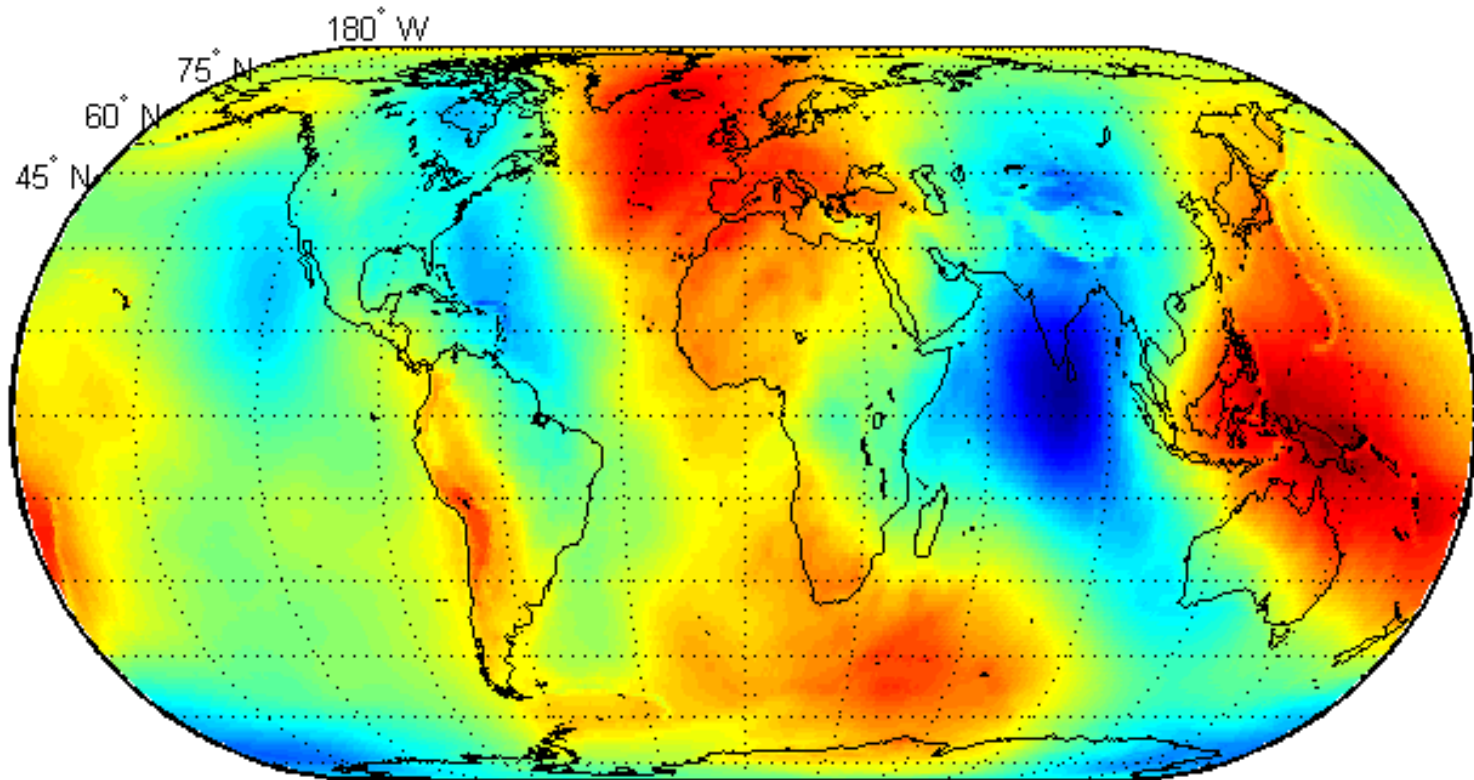

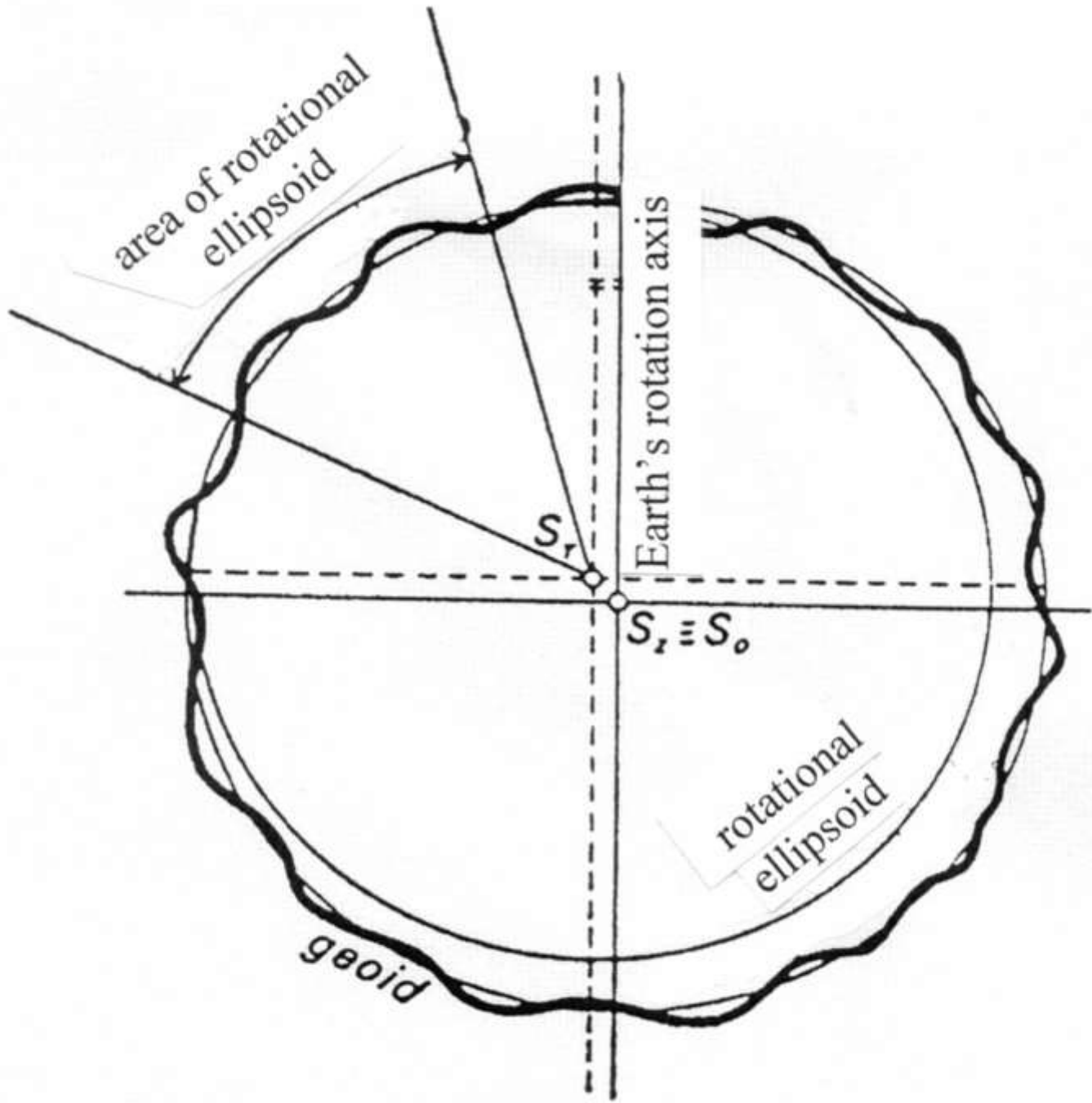

The ellipsoids used in the Czech Republic

Parameter	Bessel ellipsoid	Hayford ellipsoid	Krasovský ellipsoid	GRS-80
a (half-axis)	6 377 397,155 m	6 378 388,000 m	6 378 245,000 m	6 378 137,000 m
b (half-axis)	6 356 078,963 m	6 356 911,946 m	6 356 863,019 m	6 356 752,314 m
c (radius of curvature at the Pole)	6 398 786,849 m	6 399 936,608 m	6 399 698,902 m	6 399 593,626 m
i (flattening)	1 : 299,152	1 : 297,000	1 : 298,300	1 : 298,257

Geodetic problems with lower requirements for accuracy are solved using a **sphere** as the reference surface.

Radius of the reference sphere is about 6380 km (for Czech republic).

The last reference surface is **plane** which is applicable in smaller area (with diameter less than 30 km)

Cartographic projections

- assignment of points between reference and projection surfaces (e.g. a sphere and a plane),
- mathematical formulas for the projection have to be known.
- Error of the cartographic projection = a deformation of distances, angles or areas displayed on the map. The error is caused by a cartographic projection process.

Cartographic projections classification according to the error of the projection

- **conformal** projections – angles are undistorted
- **equidistant** projections – distances are undistorted (some of them)
- **equivalent** projections – areas are undistorted
- **compensated** projections – angles, distances and areas are distorted

World map



Reality:

Greenland (2 166 086 km²)

Australia (7 741 220 km²).

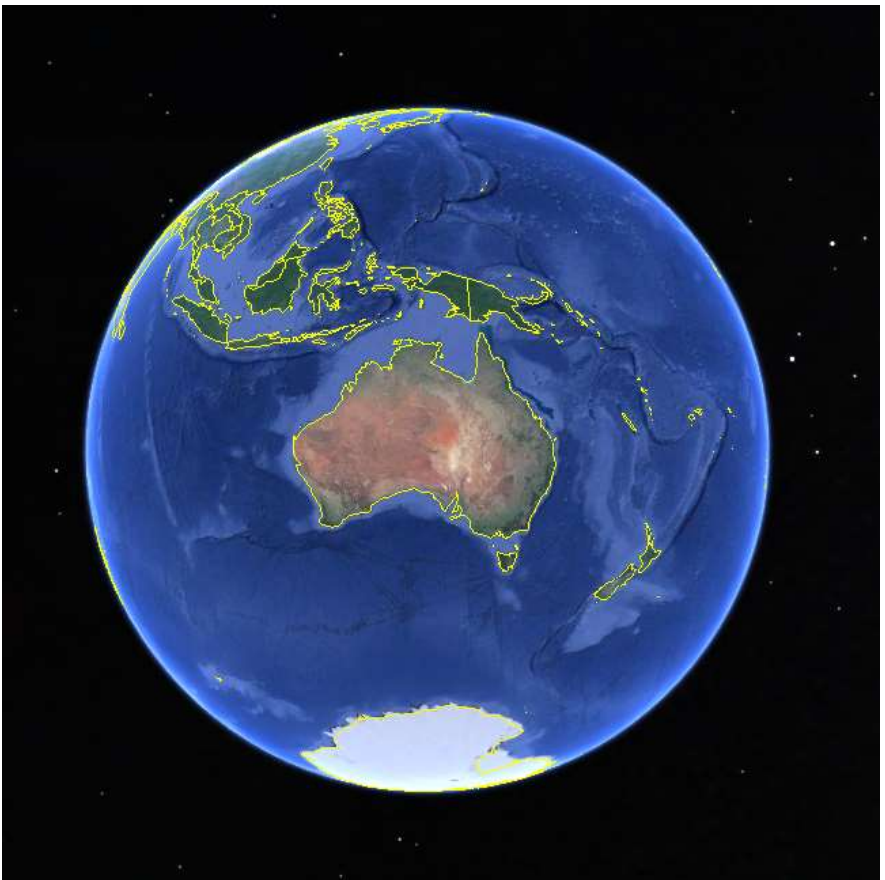

Cartographic projections classification according to the position of the projection surface

- normal position – axis of a cone or a cylinder is identical with the Earth axis
- transversal position – axis of a cone or a cylinder lies in the equator plane
- universal position

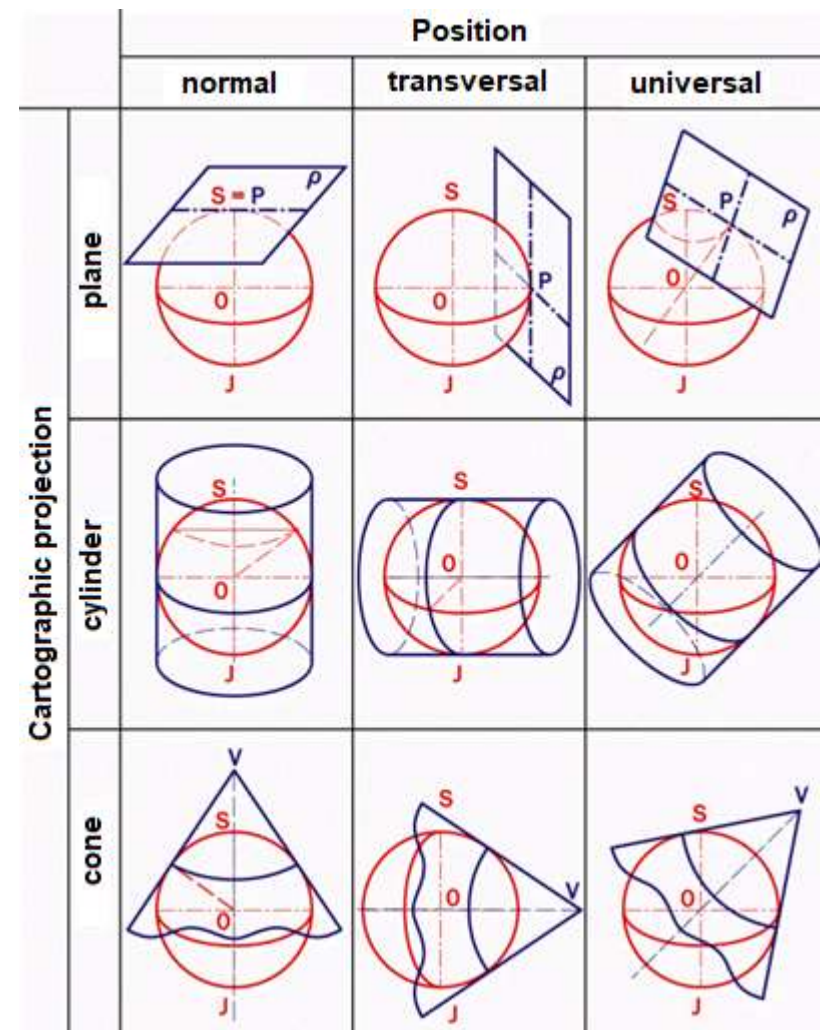

Cassini-Soldner's projection

- ellipsoid \rightarrow cylinder \rightarrow plane
- the equidistant projection of meridian zones (ellipsoid \rightarrow cylinder)
- the transversal position of the cylinder
- maps of „stable“ cadastre of 19th century in Austrian Empire (1:2880, 1:2500)
- axis +X to the south, axis +Y to the west
- 60% of contemporary cadastral maps

Cassini-Soldner's projection

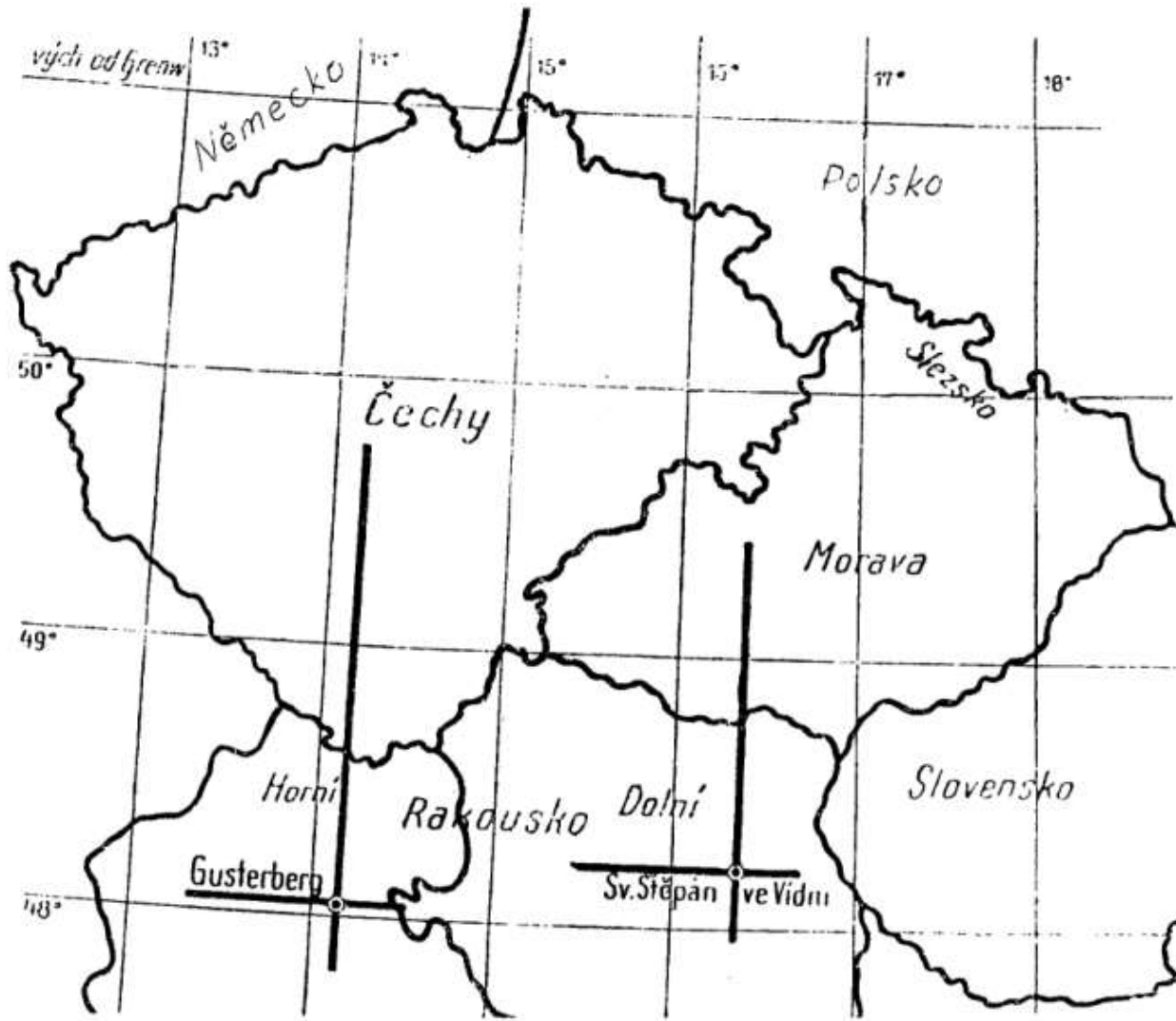

Křovák's projection

- universal conformal conic projection
(ellipsoid → sphere → cone → plane)
- national projection
- universal projection = less effect of the scale error
- the scale error is 1,0001 near the borders of the Czech Republic and 0,9999 in the middle of the territory
- axis +X to the south, axis +Y to the west
- $Y < X$
- Datum of Unified Trigonometric Cadastral Net
S – JTSK

Křovák's projection

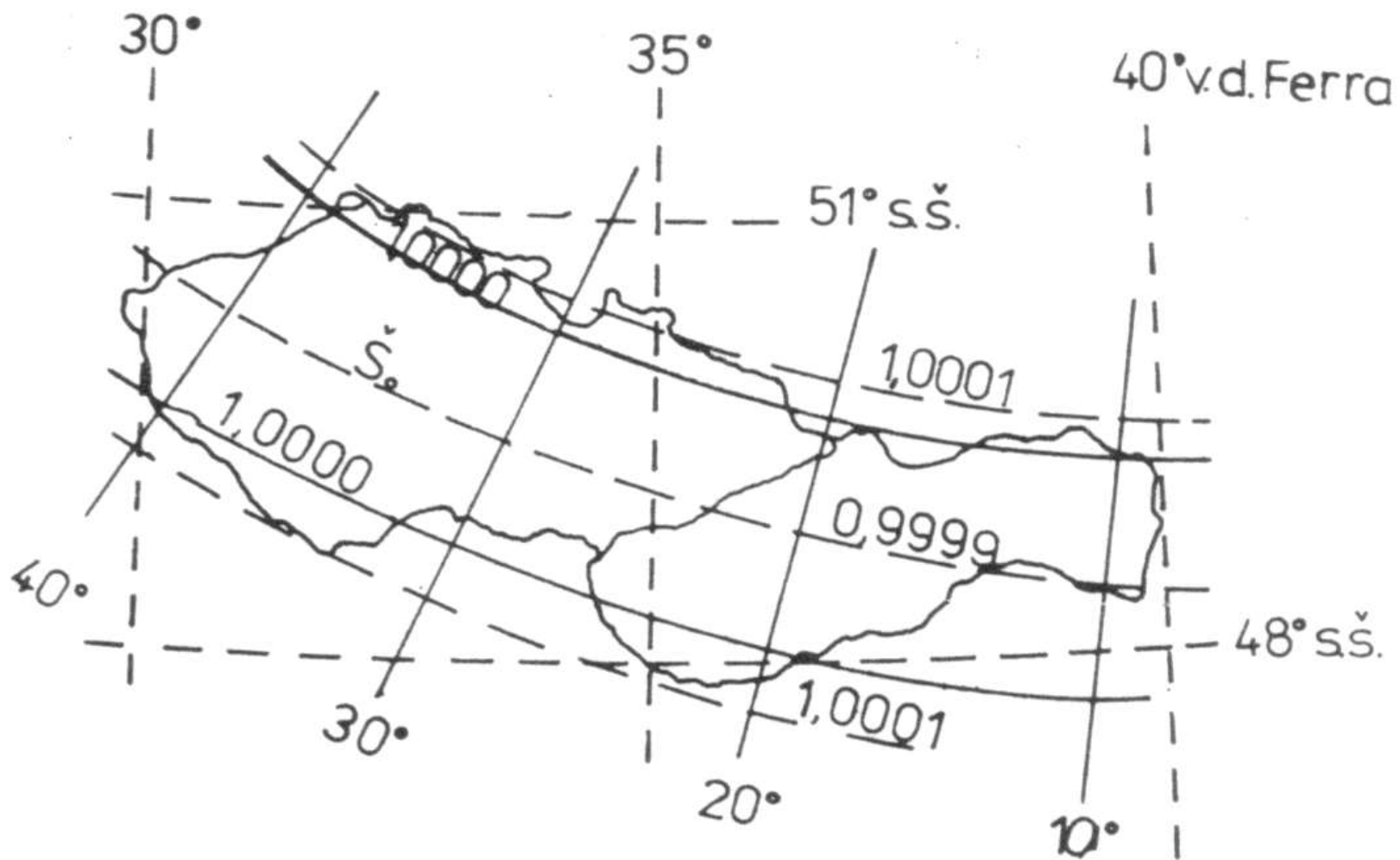

Gauss-Krüger's projection

- transversal conformal cylindrical projection of 6° wide meridian zones (ellipsoid → cylinder → plane)
- the meridian in the middle of every meridian zone is undistorted, the scale error is 1,00057 at the edges of zones
- axis +X to the north, axis +Y to the east
- this projection is used for military purposes
- 1942 coordinate system (S – 42)

Gauss-Krüger's projection

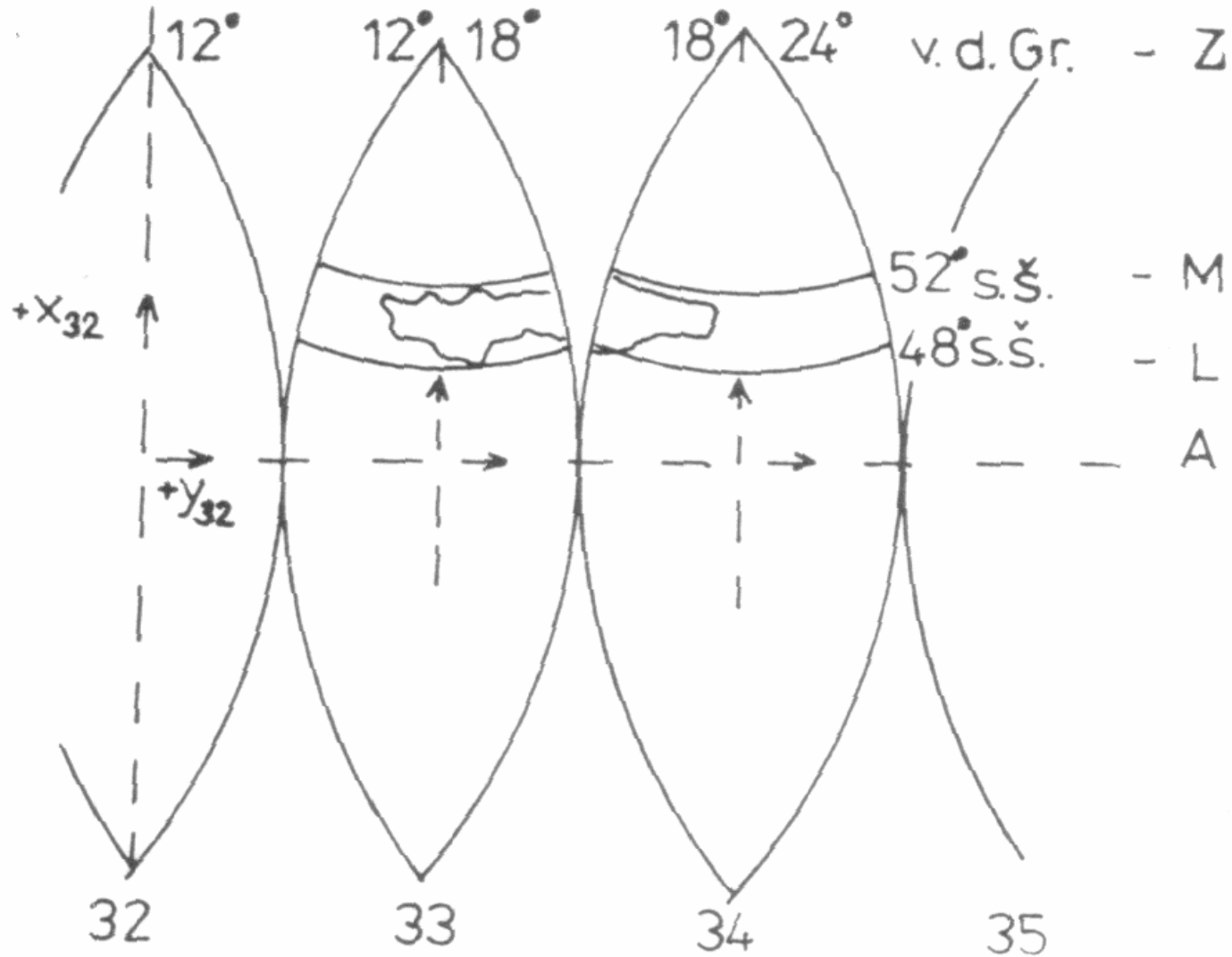

UTM's projection

- UTM – Universal Transverse Mercator
- transversal conformal cylindrical projection of 6° wide meridian zones (ellipsoid → cylinder → plane) without pole areas
- the meridian in the middle of every meridian zone has the scale error 0.9996, the edges of zones has the scale error 1.00017
- axis +N goes to the north, axis +E goes to the east
- this projection is used for military purposes

UTM's projection

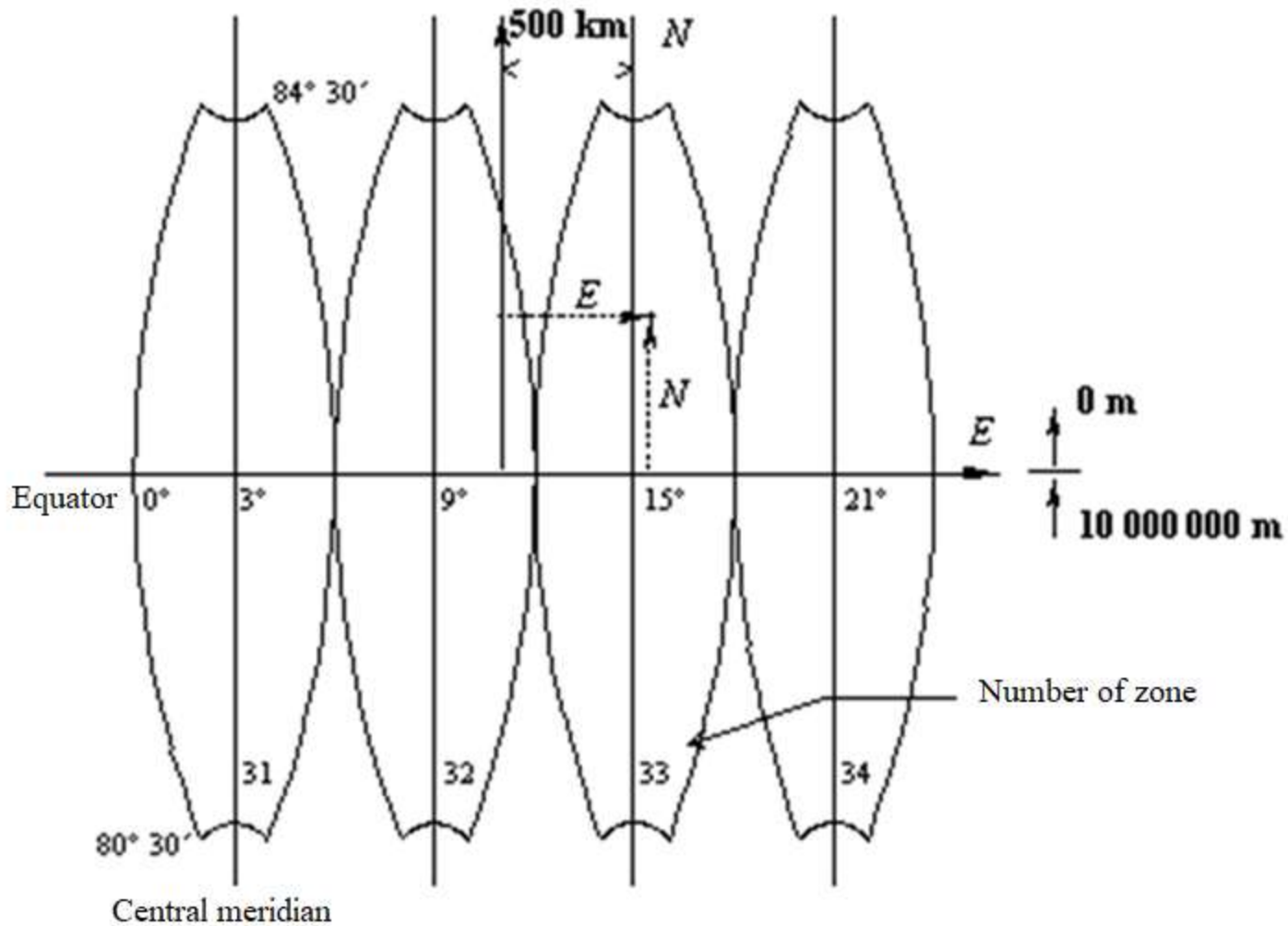

UTM's projection - zones

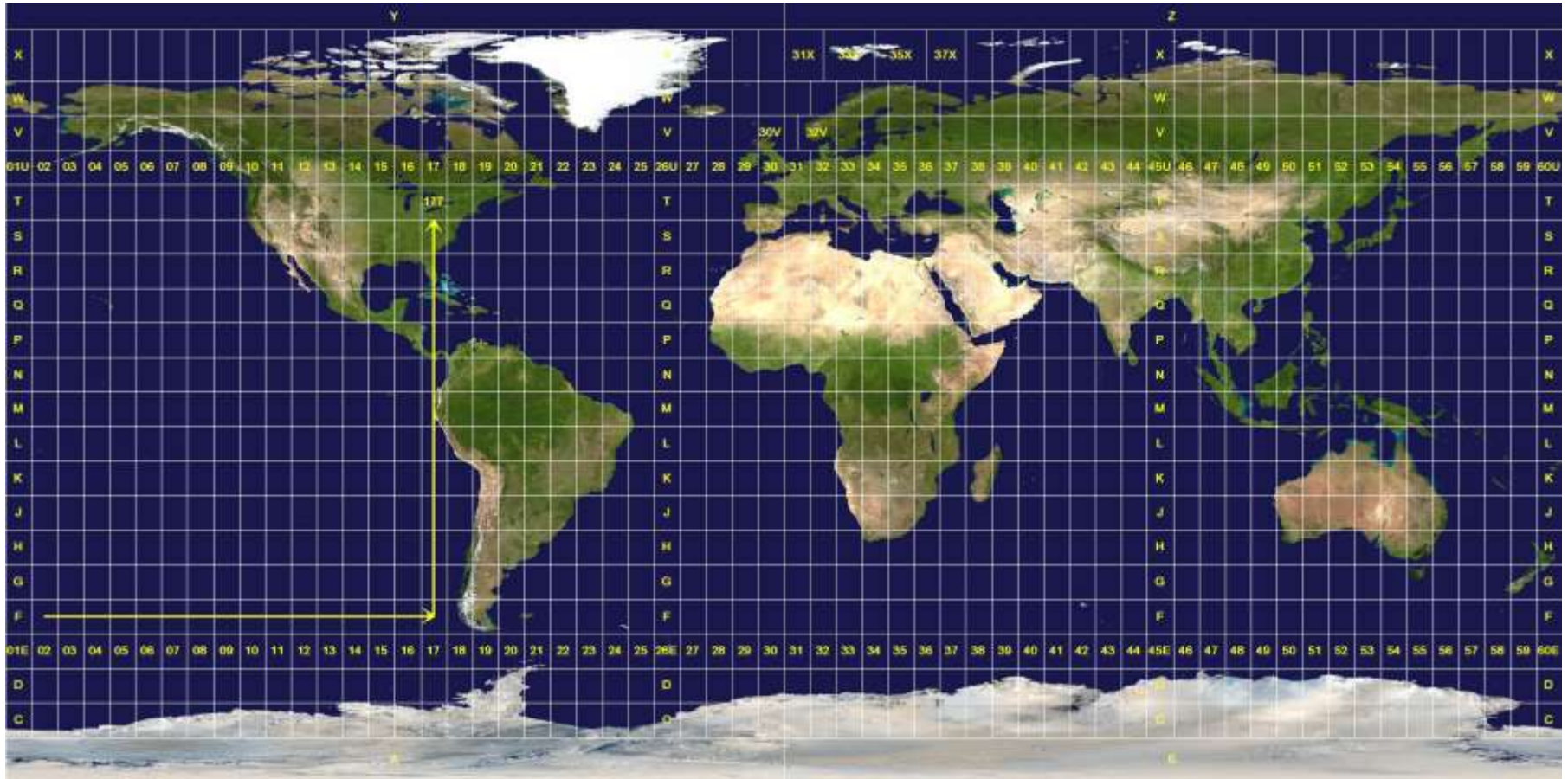

Coordinate system WGS84

- World Geodetic System 1984 – geocentric coordinate system. It is standard for use in cartography, geodesy, and satellite navigation.

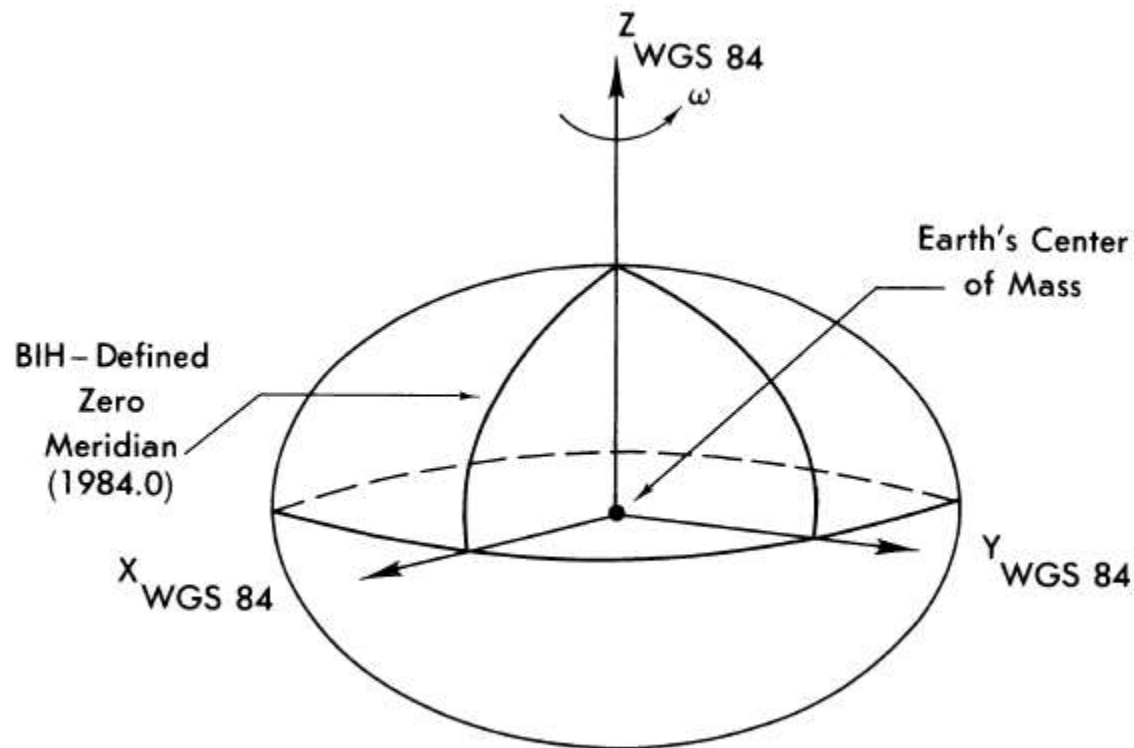

Substitution for a sphere by a plane

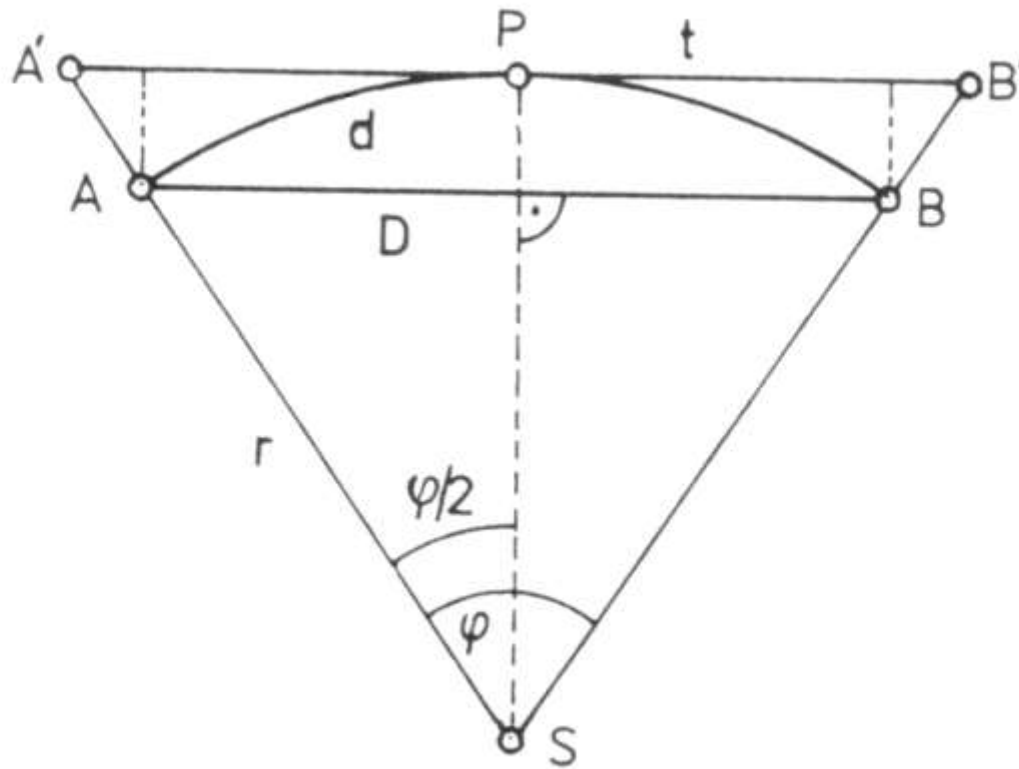

$$\varphi = d / r \quad \Rightarrow \quad d = r \cdot \varphi ,$$

$$\operatorname{tg} \varphi / 2 = t / 2 r \quad \Rightarrow \quad t = 2 r \cdot \operatorname{tg} \varphi / 2 ,$$

$$\sin \varphi / 2 = D / 2 r \quad \Rightarrow \quad D = 2 r \cdot \sin \varphi / 2 .$$

Taylor's expansion

$$\operatorname{tg} \frac{\varphi}{2} = \frac{\varphi}{2} + \frac{1}{3} \left(\frac{\varphi}{2} \right)^3 + \frac{2}{15} \left(\frac{\varphi}{2} \right)^5 + \dots = \frac{\varphi}{2} + \frac{\varphi^3}{24} + \dots$$

$$\sin \frac{\varphi}{2} = \frac{\varphi}{2} - \frac{1}{3!} \left(\frac{\varphi}{2} \right)^3 + \frac{1}{5!} \left(\frac{\varphi}{2} \right)^5 + \dots = \frac{\varphi}{2} - \frac{\varphi^3}{48} + \dots$$

$$t = 2r \left(\frac{\varphi}{2} + \frac{\varphi^3}{24} \right) = r\varphi + r \frac{\varphi^3}{12}$$

$$D = 2r \left(\frac{\varphi}{2} - \frac{\varphi^3}{48} \right) = r\varphi - r \frac{\varphi^3}{24}$$

$$t = d + \frac{d^3}{12r^2} \qquad D = d - \frac{d^3}{24r^2}$$

d [km]	d - D [mm]	t - d [mm]
1	0	0
5	0	0
10	1	2
15	4	8
20	9	19
30	31	62

Conclusion:

There is a difference between the arc and the chord 3 cm (between the tangent and the arc 6 cm) for the distance 30 km. This difference is less than errors caused by measurement therefore the sphere ($r = 6380$ km) can be replaced by a plane for the planimetric measurement on the surface with radius less than 15 km without cartographic projection.

Sea level height (elevation) influence on a measured distance

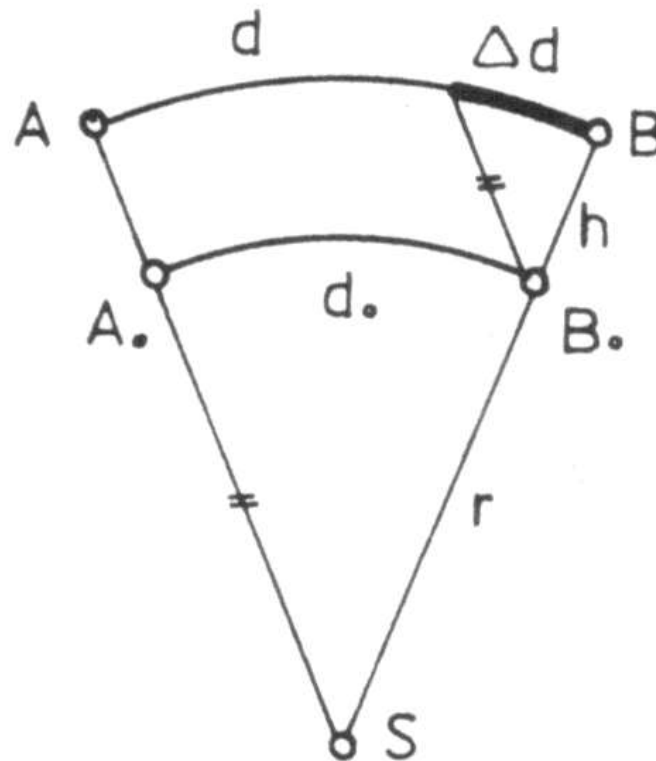

$$\frac{d}{r + h} = \frac{d_0}{r}$$

$$d_0 = d \frac{r}{r + h}$$

r ... radius of the reference sphere (6380 km)

h ... sea level height (elevation)

Distance corrections in relation to the elevation

d [m]	Δd [mm] for h = 500 m	Δd [mm] for h = 1000 m
100	8	17
200	17	33
500	42	83
1000	83	167

Conclusion:

The elevation influence on a measured distance has to be considered (it means the correction has to be calculated) for all accurate measurements.

Influence of the Earth's curvature on heights

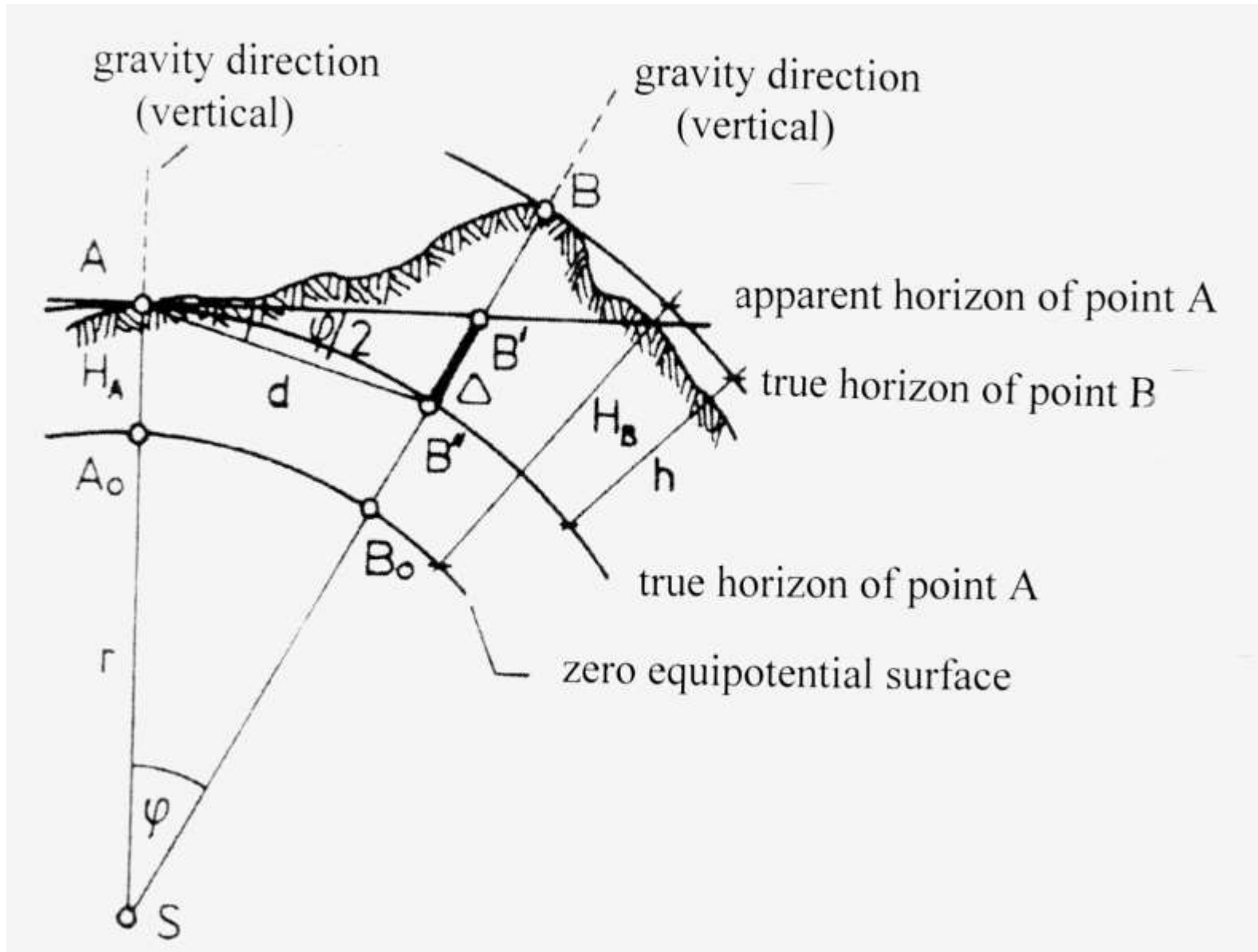

Influence of the Earth's curvature on heights

$$\Delta = d \cdot \operatorname{tg} \varphi/2 \cong d \cdot \varphi/2$$

$$\varphi/2 = d / 2r \quad \Rightarrow \quad \Delta = d^2 / 2r$$

d [m]	Δ [mm]
50	0
350	10
1000	83

Conclusion:

The influence of the Earth's curvature on heights has to be considered (it means the correction has to be calculated) for all accurate measurements.

Thank you for your attention!